

DESCRIPTION

The HI-1573 and HI-1574 are low power CMOS dual transceivers designed to meet the requirements of the MIL-STD-1553 specification.

The transmitter section of each bus takes complementary CMOS/TTL Manchester II bi-phase data and converts it to differential voltages suitable for driving the bus isolation transformer. Separate transmitter inhibit control signals are provided for each transmitter.

The receiver section of each bus converts the 1553 bus bi-phase differential data to complementary CMOS/TTL data suitable for input to a Manchester decoder. Each receiver has a separate enable input, which forces the receiver outputs to logic "0" (HI-1573) or logic "1" (HI-1574).

To minimize the package size for this function, the transmitter outputs are internally connected to the receiver inputs, so that only two pins are required for connection to each coupling transformer. For designs requiring independent access to transmitter and receiver 1553 signals, please contact your Holt Sales representative.

FEATURES

- Compliant to MIL-STD-1553A and B, ARINC 708A
- 3.3V single supply operation
- Smallest footprint available in 7 mm x 7 mm 44-pin plastic chip-scale package (QFN)
- Available in DIP and small outline (ESDIP) package options
- Industrial and extended temperature ranges
- Industry standard pin configurations

PIN CONFIGURATIONS

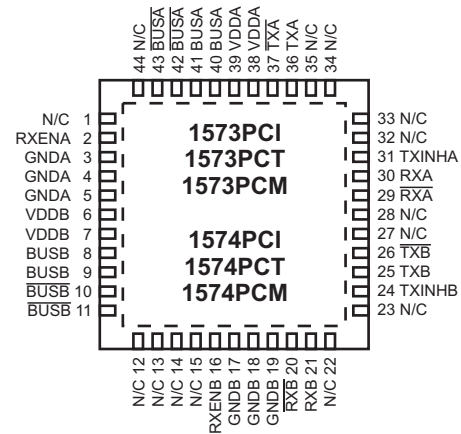

**44 Pin Plastic 7mm x 7mm
Chip-scale package (QFN)**

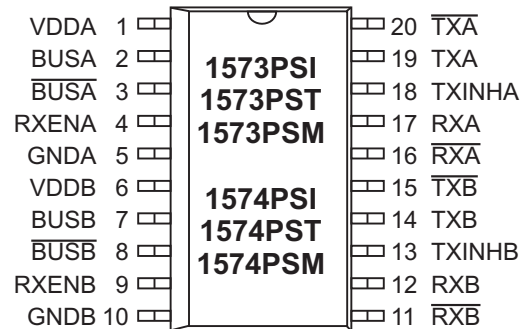

20 Pin Plastic ESOIC - WB package

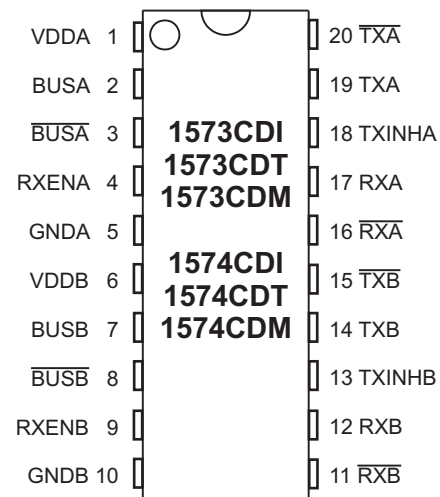

20 Pin Ceramic DIP package

PIN DESCRIPTIONS

PIN (DIP & SOIC)	SYMBOL	FUNCTION	DESCRIPTION
1	VDDA	power supply	+3.3 volt power for transceiver A
2	BUSA	analog	MIL-STD-1533 bus driver A, positive signal
3	\overline{BUSA}	analog	MIL-STD-1553 bus driver A, negative signal
4	RXENA	digital input	Receiver A enable. If low, forces RXA and \overline{RXA} low (HI-1573) or High (HI-1574)
5	GND A	power supply	Ground for transceiver A
6	VDD B	power supply	+3.3 volt power for transceiver B
7	BUSB	analog	MIL-STD-1533 bus driver B, positive signal
8	\overline{BUSB}	analog	MIL-STD-1553 bus driver B, negative signal
9	RXEN B	digital input	Receiver B enable. If low, forces RXB and \overline{RXB} low (HI-1573) or High (HI-1574)
10	GND B	power supply	Ground for transceiver B
11	\overline{RXB}	digital output	Receiver B output, inverted
12	RXB	digital output	Receiver B output, non-inverted
13	TXINH B	digital input	Transmit inhibit, bus B. If high BUSB, \overline{BUSB} disabled
14	TXB	digital input	Transmitter B digital data input, non-inverted
15	\overline{TXB}	digital input	Transmitter B digital data input, inverted
16	\overline{RXA}	digital output	Receiver A output, inverted
17	RXA	digital output	Receiver A output, non-inverted
18	TXINH A	digital input	Transmit inhibit, bus A. If high BUSA, \overline{BUSA} disabled
19	TXA	digital input	Transmitter A digital data input, non-inverted
20	\overline{TXA}	digital input	Transmitter A digital data input, inverted

FUNCTIONAL DESCRIPTION

The HI-1573 family of data bus transceivers contains differential voltage source drivers and differential receivers. They are intended for applications using a MIL-STD-1553 A/B data bus. The device produces a trapezoidal output waveform during transmission.

TRANSMITTER

Data input to the device's transmitter section is from the complementary CMOS inputs TXA/B and $\overline{TXA/B}$. The transmitter accepts Manchester II bi-phase data and converts it to differential voltages on BUSA/B and $\overline{BUSA/B}$. The transceiver outputs are either direct- or transformer-coupled to the MIL-STD-1553 data bus. Both coupling methods produce a nominal voltage on the bus of 7.5 volts peak to peak.

The transmitter is automatically inhibited and placed in the high impedance state when both TXA/B and $\overline{TXA/B}$ are driven with the same logic state. A logic "1" applied to the TXINH A/B input will force the transmitter to the high impedance state, regardless of the state of TXA/B and $\overline{TXA/B}$.

RECEIVER

The receiver accepts bi-phase differential data from the MIL-STD-1553 bus through the same direct- or transformer-coupled interface as the transmitter.

The receiver's differential input stage drives a filter and threshold comparator that produces CMOS data at the RXA/B and $\overline{RXA/B}$ output pins. When the MIL-STD-1553 bus is idle and RXENA or RXENB are high, RXA/B will be logic "0" on HI-1573 and logic "1" on HI-1574.

The receiver outputs are forced to the bus idle state (logic "0" on HI-1573 or logic "1" on HI-1574) when RXENA or RXENB is low.

MIL-STD-1553 BUS INTERFACE

A direct-coupled interface (see Figure 2) uses a 1:2.5 ratio isolation transformer and two 55 ohm isolation resistors between the transformer and the bus. The primary center-tap of the isolation transformer must be connected to GND.

In a transformer-coupled interface (see Figure 2), the transceiver is connected to a 1:1.79 isolation transformer which in turn is connected to a 1:1.4 coupling transformer. The transformer-coupled method also requires two coupling resistors equal to 75% of the bus characteristic impedance (Z_0) between the coupling transformer and the bus.

Figure 3 and Figure 4 show test circuits for measuring electrical characteristics of both direct- and transformer-coupled interfaces respectively. (See electrical characteristics on the following pages).

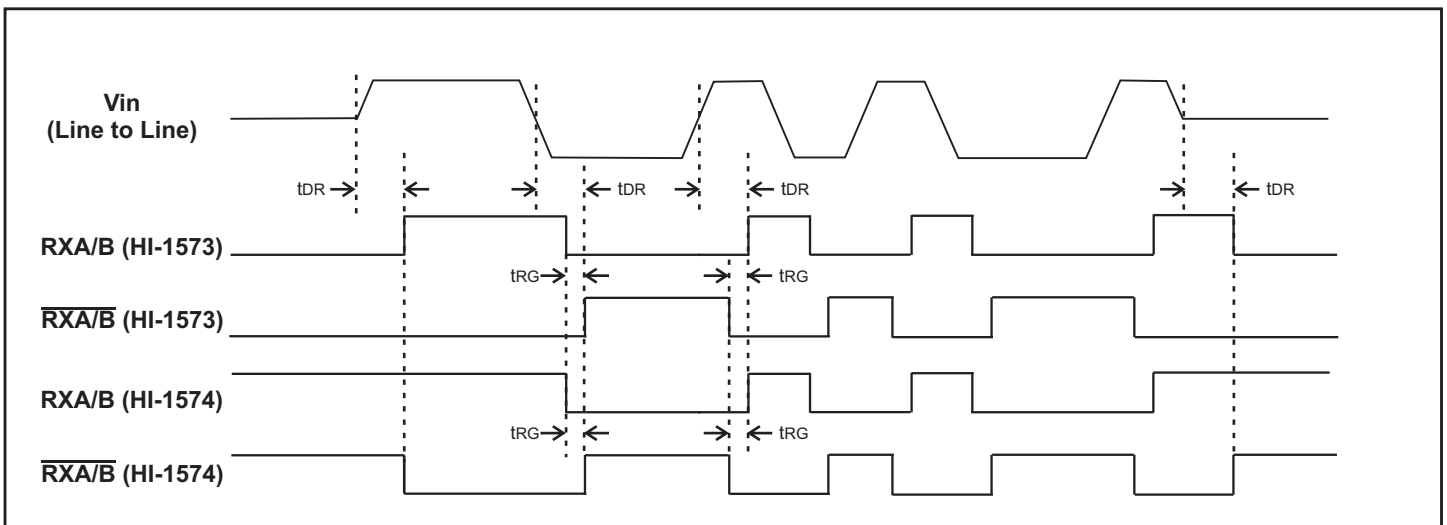
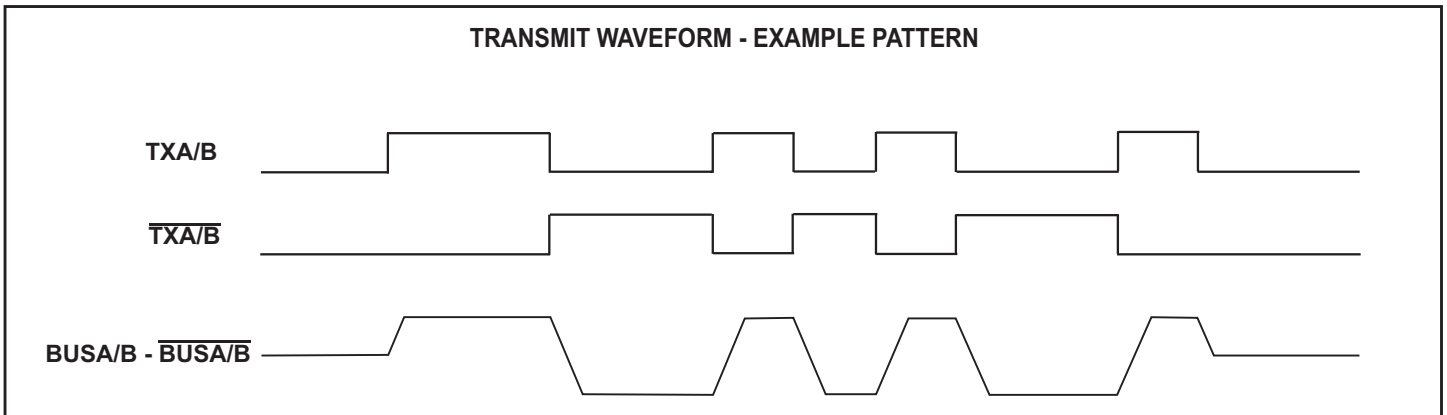
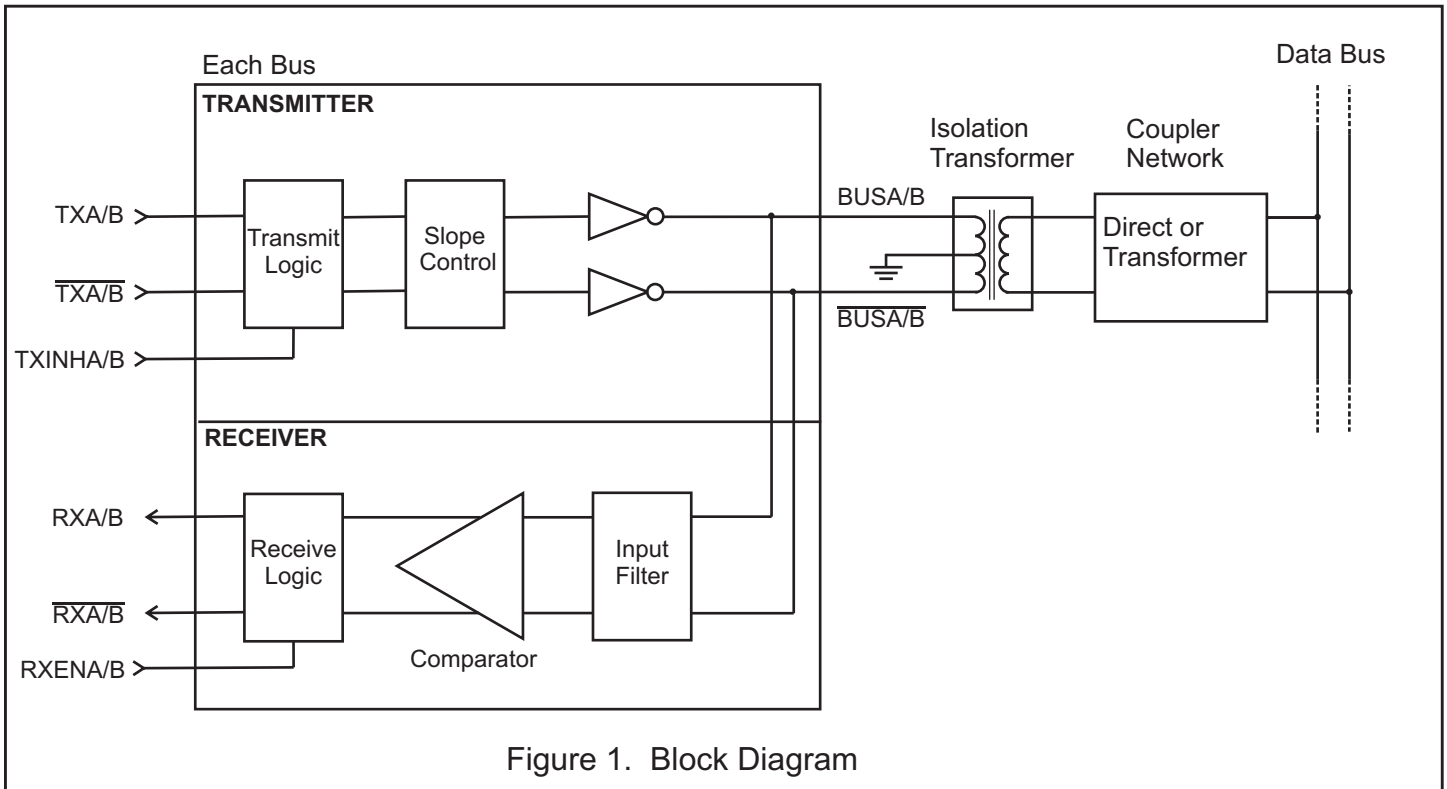

ABSOLUTE MAXIMUM RATINGS

Supply voltage (VDD)	-0.3 V to +5 V
Logic input voltage range	-0.3 V dc to +3.6 V
Receiver differential voltage	50 Vp-p
Driver peak output current	+1.0 A
Solder Reflow Temperature	260°C
Junction Temperature	175°C
Storage Temperature	-65°C to +150°C

RECOMMENDED OPERATING CONDITIONS

Supply Voltage	VDD..... 3.3V... ±5%
Temperature Range	Industrial-40°C to +85°C Extended.....-55°C to +125°C

NOTE: Stresses above absolute maximum ratings or outside recommended operating conditions may cause permanent damage to the device. These are stress ratings only. Operation at the limits is not recommended.

DC ELECTRICAL CHARACTERISTICS

VDD = 3.3 V, GND = 0V, TA = Operating Temperature Range (unless otherwise specified).

PARAMETER	SYMBOL	CONDITION	MIN	TYP	MAX	UNITS
Operating Voltage	VDD		3.15	3.30	3.45	V
Total Supply Current	ICC1	Not Transmitting		10	17	mA
	ICC2	Transmit one bus @ 50% duty cycle		210	225	mA
	ICC3	Transmit one bus @ 100% duty cycle		420	450	mA
Power Dissipation	PD1	Not Transmitting		0.033	0.060	W
	PD2	Transmit one bus @ 100% duty cycle		0.475	0.55	W
Min. Input Voltage (HI)	V _{IH}	Digital inputs	70%			VDD
Max. Input Voltage (LO)	V _{IL}	Digital inputs			30%	VDD
Min. Input Current (HI)	I _{IH}	Digital inputs			20	µA
Max. Input Current (LO)	I _{IL}	Digital inputs	-20			µA
Min. Output Voltage (HI)	V _{OH}	I _{OUT} = -1.0mA, Digital outputs	90%			VDD
Max. Output Voltage (LO)	V _{OL}	I _{OUT} = 1.0mA, Digital outputs			10%	VDD

RECEIVER (Measured at Point "Ad" in Figure 3 unless otherwise specified)

Input resistance	R _{IN}	Differential (at chip pins)	20			Kohm	
Input capacitance	C _{IN}	Differential			5	pF	
Common mode rejection ratio	CMRR		40			dB	
Input Level	V _{IN}	Differential			9	Vp-p	
Input common mode voltage	V _{ICM}		-5.0		5.0	V-pk	
Threshold Voltage - Direct-coupled	Detect	V _{THD}	1 Mhz Sine Wave Measured at Point "Ad" in Figure 3 RXA/B, $\overline{RXA/B}$ pulse width >70 ns	1.15			Vp-p
	No Detect	V _{THND}	No pulse at RXA/B, $\overline{RXA/B}$			0.28	Vp-p
Threshold Voltage - Transformer-coupled	Detect	V _{THD}	1 MHz Sine Wave Measured at Point "At" in Figure 4 RXA/B, $\overline{RXA/B}$ pulse width >70 ns	0.86			Vp-p
	No Detect	V _{THND}	No pulse at RXA/B, $\overline{RXA/B}$			0.20	Vp-p

DC ELECTRICAL CHARACTERISTICS (cont.)

VDD = 3.3 V, GND = 0V, TA = Operating Temperature Range (unless otherwise specified).

PARAMETER	SYMBOL	CONDITION	MIN	TYP	MAX	UNITS
TRANSMITTER (Measured at Point "Ab" in Figure 3 unless otherwise specified)						
Output Voltage	Direct coupled	V _{OUT}	35 ohm load (Measured at Point "Ab" in Figure 3)	6.0	9.0	Vp-p
	Transformer coupled	V _{OUT}	70 ohm load (Measured at Point "At" in Figure 4)	18.0	27.0	Vp-p
Output Noise		V _{ON}	Differential, inhibited		10.0	mVp-p
Output Dynamic Offset Voltage	Direct coupled	V _{DYN}	35 ohm load (Measured at Point "Ab" in Figure 3)	-90	90	mV
	Transformer coupled	V _{DYN}	70 ohm load (Measured at Point "At" in Figure 4)	-250	250	mV
Output resistance		R _{OUT}	Differential, not transmitting	10		Kohm
Output Capacitance		C _{OUT}	1 MHz sine wave		15	pF

AC ELECTRICAL CHARACTERISTICS

VDD = 3.3 V, GND = 0V, TA = Operating Temperature Range (unless otherwise specified).

PARAMETER	SYMBOL	TEST CONDITIONS	MIN	TYP	MAX	UNITS
RECEIVER (Measured at Point "At" in Figure 4)						
Receiver Delay	t _{DR}	From input zero crossing to RXA/B or $\overline{RXA/B}$			500 Note 3	ns
Receiver gap time	t _{RG}	Spacing between RXA/B and $\overline{RXA/B}$ pulses	60 Note 1		430 Note 2	ns
Receiver Enable Delay	t _{REN}	From RXENA/B rising or falling edge to RXA/B or $\overline{RXA/B}$			40	ns
TRANSMITTER (Measured at Point "Ab" in Figure 3)						
Driver Delay	t _{DT}	TXA/B, $\overline{TXA/B}$ to BUSA/B, $\overline{BUSA/B}$			150	ns
Rise time	t _r	35 ohm load	100		300	ns
Fall Time	t _f	35 ohm load	100		300	ns
Inhibit Delay	t _{DI-H}	Inhibited output			100	ns
	t _{DI-L}	Active output			150	ns

Note 1. Measured using a 1 MHz sinusoid, 20 V peak to peak, line to line at point "AT" (Guaranteed but not tested).

Note 2. Measured using a 1 MHz sinusoid, 860 mV peak to peak, line to line at point "AT" (100% tested).

Note 3. Measured using a 1 MHz sinusoid, 860 mV peak to peak, line to line at point "AT". Measured from input zero crossing point.

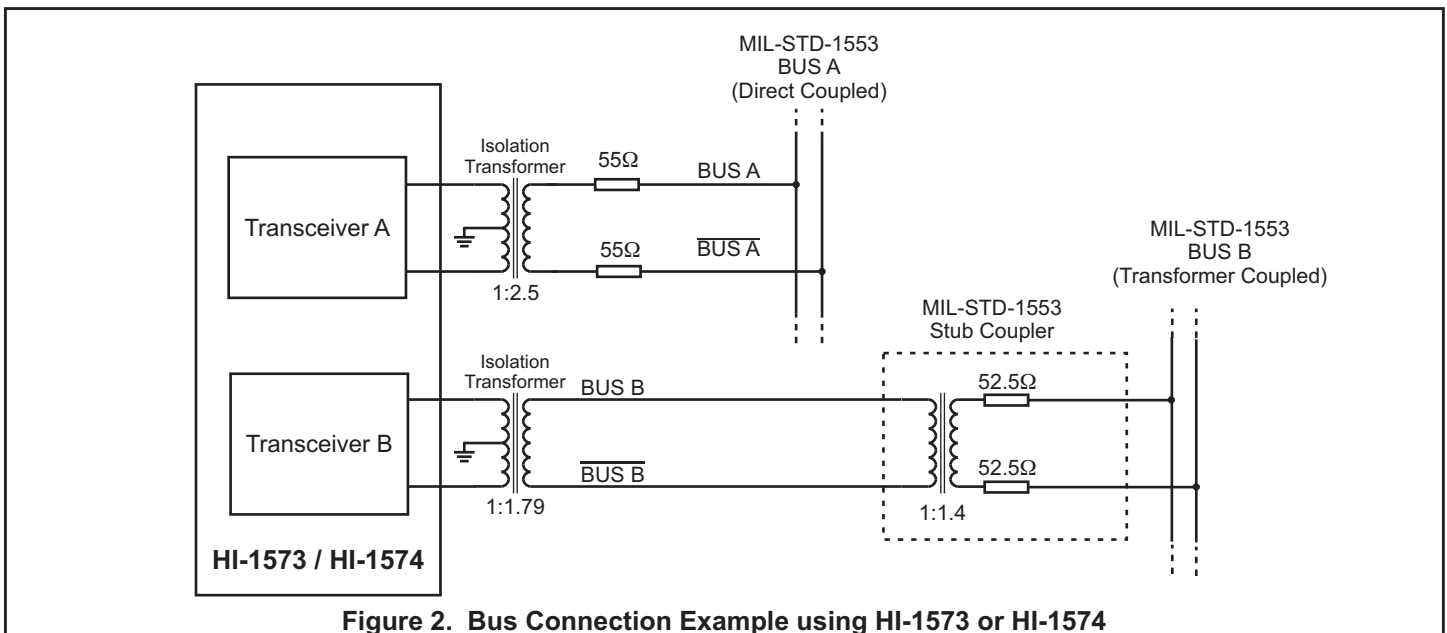

Figure 2. Bus Connection Example using HI-1573 or HI-1574

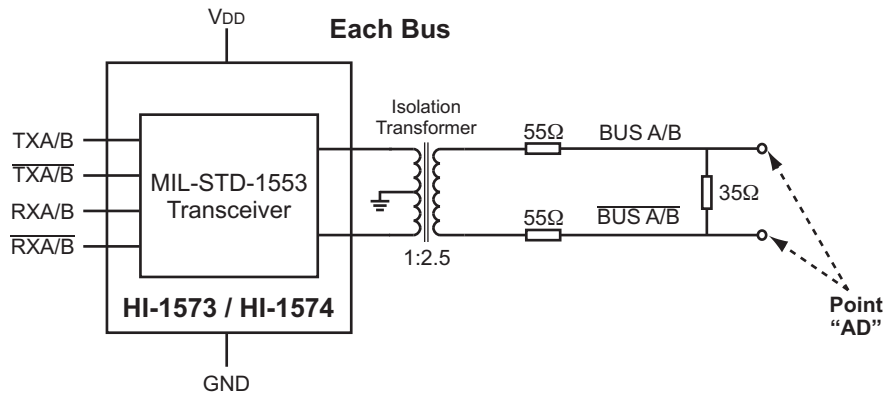

Figure 3. Direct Coupled Test Circuit

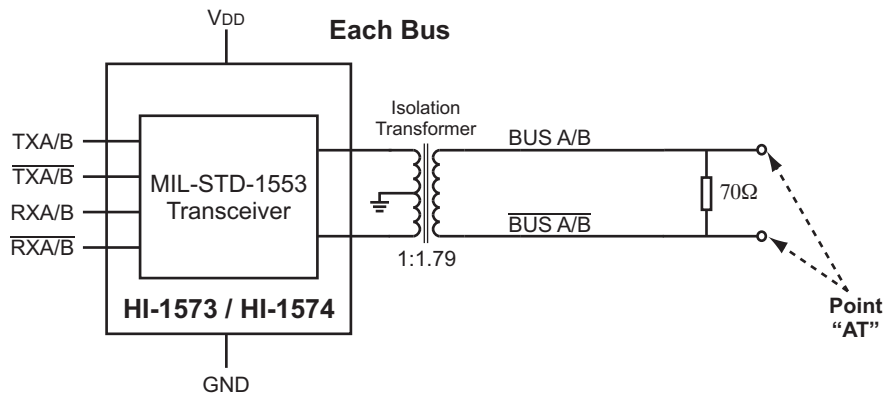

Figure 4. Transformer Coupled Test Circuit

HEAT SINK - ESOIC & CHIP-SCALE APPLICATIONS NOTE PACKAGE

Both the HI-1573PSI/T/M and HI-1574PSI/T/M use a 20-pin thermally enhanced SOIC package. The HI-1573PCI/T/M and HI-1574PCI/T/M use a plastic chip-scale package (QFN). These packages include a metal heat sink located on the bottom surface of the device. This heat sink should be soldered down to the printed circuit board for optimum thermal dissipation.

The heat sink is electrically isolated and may be soldered to any convenient power or ground plane.

Holt Applications Note AN-500 provides circuit design notes regarding the use of Holt's family of MIL-STD-1553 transceivers. Layout considerations, as well as recommended interface and protection components are included.

ORDERING INFORMATION

HI - 157x PS x x (Plastic)

PART NUMBER	PACKAGE DESCRIPTION
Blank	Tin / Lead (Sn / Pb) Solder
F	100% Matte Tin (Pb-free RoHS compliant)

PART NUMBER	TEMPERATURE RANGE	FLOW	BURN IN
I	-40°C TO +85°C	I	No
T	-55°C TO +125°C	T	No
M	-55°C TO +125°C	M	Yes

PART NUMBER	PACKAGE DESCRIPTION
PS	20 PIN PLASTIC ESOIC, Thermally Enhanced Wide SOIC w/Heat Sink (20HWE)

PART NUMBER	RXENA = 0		RXENB = 0	
	RXA	\overline{RXA}	RXB	\overline{RXB}
1573	0	0	0	0
1574	1	1	1	1

ORDERING INFORMATION

HI - 157x PC x x (Plastic)

PART NUMBER	PACKAGE DESCRIPTION
Blank	NiPdAu
F	NiPdAu (Pb-free RoHS compliant)

PART NUMBER	TEMPERATURE RANGE	FLOW	BURN IN
I	-40°C TO +85°C	I	No
T	-55°C TO +125°C	T	No
M	-55°C TO +125°C	M	Yes

PART NUMBER	PACKAGE DESCRIPTION
PC	44 PIN PLASTIC CHIP-SCALE PACKAGE QFN (44PCS)

PART NUMBER	RXENA = 0		RXENB = 0	
	RXA	RXĀ	RXB	RXB̄
1573	0	0	0	0
1574	1	1	1	1

HI - 157xCD x (Ceramic)

PART NUMBER	TEMPERATURE RANGE	FLOW	BURN IN	LEAD FINISH
I	-40°C TO +85°C	I	No	Gold (Pb-free, RoHS compliant)
T	-55°C TO +125°C	T	No	Gold (Pb-free, RoHS compliant)
M	-55°C TO +125°C	M	Yes	Tin / Lead (Sn / Pb) Solder

PART NUMBER	RXENA = 0		RXENB = 0		PACKAGE DESCRIPTION
	RXA	RXĀ	RXB	RXB̄	
1573	0	0	0	0	20 PIN CERAMIC SIDE BRAZED DIP (20C)
1574	1	1	1	1	20 PIN CERAMIC SIDE BRAZED DIP (20C)

RECOMMENDED TRANSFORMERS

The HI-1573 and HI-1574 transceivers have been characterized for compliance with the electrical requirements of MIL-STD-1553 when used with the following

transformers. Holt recommends the Premier Magnetics parts as offering the best combination of electrical performance, low cost and small footprint.

MANUFACTURER	PART NUMBER	APPLICATION	TURNS RATIO(S)	DIMENSIONS
Premier Magnetics	PM-DB2725EX	Isolation	Dual ratio 1:1.79, 1:2.5	0.4 x 0.4 x 0.242 inches
Premier Magnetics	PM-DB2702	Stub coupling	1:1.4	.625 x .625 x .250 inches
Premier Magnetics	PM-DB-2791S	Isolation	1:2.5	0.4 x 0.4 x 0.185 inches
Premier Magnetics	PM-DB-2795S	Isolation	1:1.79	0.4 x 0.4 x 0.185 inches
Premier Magnetics	PM-DB-2798S	Isolation	Dual ratio 1:1.79, 1:2.5	0.4 x 0.4 x 0.185 inches
Premier Magnetics	PM-DB-2762	Isolation	Dual core 1:2.5	0.4 x 0.4 x 0.320 inches
Premier Magnetics	PM-DB-2766	Isolation	Dual core 1:1.79	0.4 x 0.4 x 0.320 inches

REVISION HISTORY

Document	Rev.	Date	Description of Change
DS1573	L	09/26/08	Clarification of transmitter and receiver functions in Description, clarification of available temperature ranges, and corrected a dimension in Recommended Transformers table.
	M	04/13/09	Add 'M' Flow option to chip-scale package (QFN). Clarify nomenclature of chip-scale package as QFN.
	N	07/24/09	Correct typographical errors in package dimensions.
	O	10/13/09	Clarified status of RXA/B and $\overline{\text{RXA/B}}$ pins in bus idle state when RXENA or RXENB are high (logic "1").
	P	01/26/12	Fix typos in tRG and tDT descriptions in AC characteristics table. Added latest Premier Magnetics transformer recommendations. Remove Technotrol transformer recommendations.
	Q	06/20/13	Updated functional description text for clarity. Revised figures 2,3, and 4. Updated package drawings.
	R	05/21/14	Updated Figure 2 and package drawings.
	S	04/09/15	Correct Figures 2 and 3. Other minor clarifications.
	T	06/06/17	Update Power Dissipation and Power Supply Current parameters.
	U	11/29/17	Correct typo in DC Electrical Characteristics Table; VOL incorrectly labeled as VIH. Remove Power Dissipation from Absolute Maximum Ratings Table. Remove Thermal Characteristics Table. Refer to website for thermal resistance data.
	V	08/25/2020	Update QFN package lead finish to NiPdAu.

20-PIN PLASTIC SMALL OUTLINE (ESOC) - WB
(Wide Body, Thermally Enhanced)

millimeters (inches)

Package Type: 20HWE

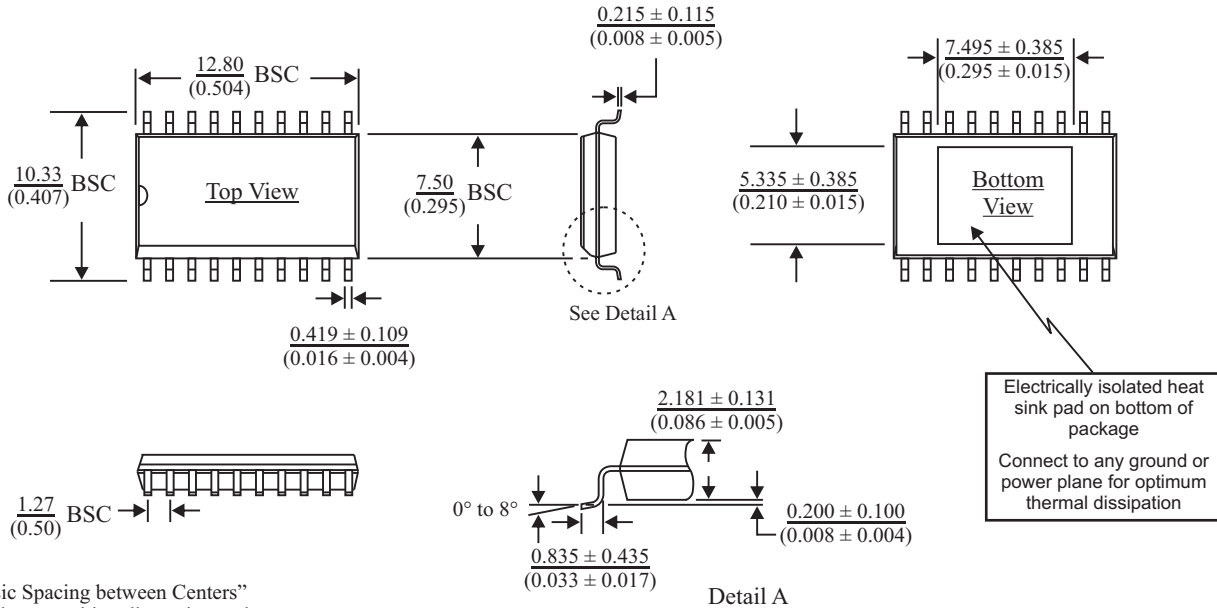

BSC = "Basic Spacing between Centers" is theoretical true position dimension and has no tolerance. (JEDEC Standard 95)

20-PIN CERAMIC SIDE-BRAZED DIP

inches (millimeters)

Package Type: 20C

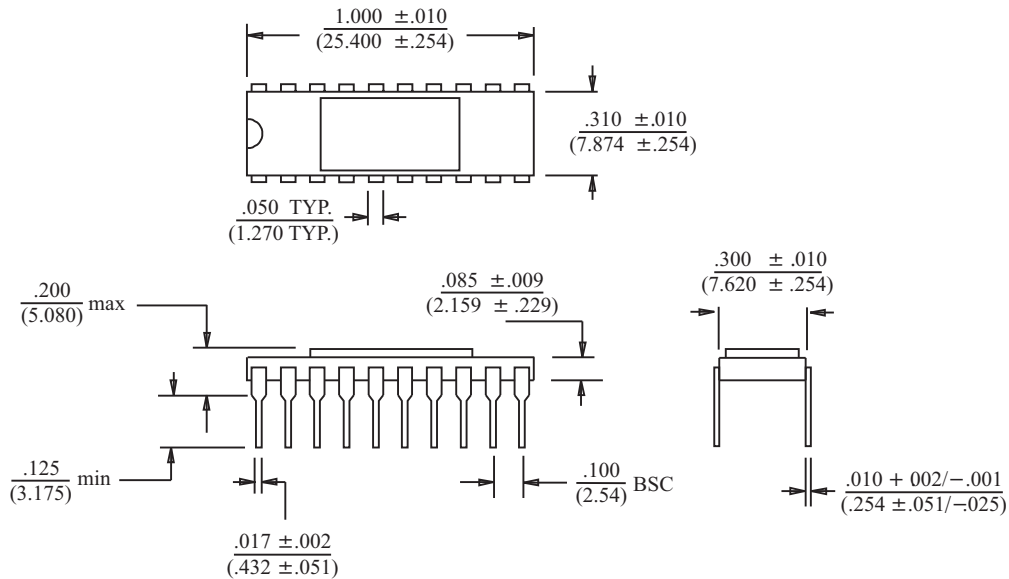

BSC = "Basic Spacing between Centers" is theoretical true position dimension and has no tolerance. (JEDEC Standard 95)

44-PIN PLASTIC CHIP-SCALE PACKAGE (QFN)

millimeters (inches)

Package Type: 44PCS

